



FortiVoice™

FVC Hardware
Specification Guide

FortiVoice FVC Hardware Specification Guide

Revision 2

7 February 2012

© Copyright 2012 Fortinet, Inc. All rights reserved. Contents and terms are subject to change by Fortinet without prior notice.

Trademarks

The names of actual companies and products mentioned herein may be the trademarks of their respective owners.

Visit these links for more information and documentation for your Fortinet product:

Technical Documentation - <http://docs.fortinet.com>

Fortinet Knowledge Center - <http://kb.fortinet.com>

Technical Support - <http://www.fortinet.com/fortivoice>

Training Services - <http://training.fortinet.com>

TABLE OF CONTENTS

INTRODUCTION	1
What you should know	1
Important information	1
Electrical shock	1
Power and lightning surge protection	2
Power adapter and power cord	2
Power failure	2
What happens if the power goes out or if the IP network to VoIP fails?	2
External audio source isolation	2
Cleaning	2
SPECIFICATIONS	3
Interfaces	3
Interface Specifications	3
Analog Extension Specifications	4
Telephone Line Specifications	4
Dimensions	4
Weight	4
Regulatory Approvals	5
VoIP Features	5
INSTALLATION	6
Upgrading systems	6
Unit front panel	6
What the flashing lights mean	7
Unit back panel	7
HOME/OFFICE WIRING INSTRUCTIONS	8
Basic residential phone wiring	8
Looped wiring	8
Single-line wiring	8
Two-line wiring	8
Demarcation point	9
Home and home office wiring prior to adding your phone system	10

SAFETY AND REGULATORY INFORMATION	13
Safety Precautions.....	13
External audio source isolation	13
Important Notices	14
CE Compliance	14
FCC and IC Warnings.....	14
FCC Part 15	14
ACTA TIA/EIA/IS-968A, FCC Part 68 and IC CS-03.....	14
DOC Compliance.....	15
ICASA.....	15
RoHS Compliance.....	16
Disposal	16

INTRODUCTION

The phone system you have purchased is designed and supplied to meet the technical standards for use in specific countries and for connection to the major telephone service providers in those countries. It is subject to regulatory certification and compliances.

WHAT YOU SHOULD KNOW

While the phone system is customer installable, certain skills are required if you need to route cables or to configure a network. The following points will help you determine the required skills:

- Configuring the system using the Management software can be performed by anyone with basic computer skills once the system is physically installed with proper networking equipment configurations (if two or more units are networked on a LAN).
- While most buildings are wired to accommodate the system setup, the need to route telephone and/or network cabling can occur occasionally. If your organization does not have someone with this skill set, we recommend the use of an outside telephony system technician.
- You may need to connect the system to network equipment such as a router, switch or hub with a connection to the Internet, and to configure a firewall, computer and the system for networked use internally and with Internet. If your organization does not have someone with this IT skill set, we recommend the use of an outside IT technician.

If you are installing a single, non-VoIP system, anyone with basic computer skills can use the *FortiVoice Start Guide* and this guide to perform a full installation and configuration.

Phone system installations can be categorized into some general configurations, such as single unit installation, networked units installation, VoIP or non-VoIP installation, etc. This section helps you determine your best possible plan of action using this guide, according to your installation type. While not every possible installation scenario is detailed below, determine which one better fits your situation and use its guidelines as a starting point. For solutions to common problems, please refer to Chapter 6: *Troubleshooting and Support* in the *FortiVoice User Guide*.

IMPORTANT INFORMATION

Electrical shock

Do not open the enclosure, except as instructed to install an upgrade kit. When installing an upgrade kit, disconnect the power adapter and all other cables before removing the enclosure cover, and replace the cover before reconnecting the power adapter.

Do not expose the system to any liquids; that can pose a risk of electrical shock.

Power and lightning surge protection

Surge protection devices are recommended to protect the system in areas subject to lightning or power surges. Please consult your reseller for recommended surge protection devices.

If the system has been supplied with surge protection devices to meet local regulatory requirements, these devices must be installed as described in their installation instructions.

Do not connect or disconnect any telephone lines during thunderstorms.

Power adapter and power cord

Use only the power adapter and power cord supplied with your phone system. Check that the supply voltage matches the rating on the power adapter label. If your supply voltage does not match the power adapter rating, please consult your reseller.

For safe operation, connect the supplied ground cable to the screw post on the back of the phone system (GND) and the other end to the screw of the face plate of an outlet.

Power failure

The equipment will not operate when mains power fails.

In the event of a power failure, each phone system will connect extension E4 to phone Line 1 to permit calls (except-AU models). Calls must be dialed without a hunt group. All other system functions will not be available until power is restored. We recommend that a telephone that does not depend on mains power be available for emergency use.

What happens if the power goes out or if the IP network to VoIP fails?

To ensure a reliable network connection, all elements of the VoIP network should be connected to back-up power supplies (UPS). These elements should include LAN switches, routers, firewalls, broadband connection devices (i.e. cable modems, DSL modems), and VoIP devices. If the power goes out at the Internet Service Provider, no VoIP calls can be made. Calls can still be placed over the telephone lines.

External audio source isolation

We recommend that any external audio source be connected to the system using an approved Line Isolation Unit (e.g. A-Tick () approved in AU).

Cleaning

Use a slightly moistened cloth or an anti-static cloth to clean the system. Do not use any solvents. Never use a dry cloth; electrostatic charges could damage the electronics in the system. Ensure, however, that no moisture penetrates into the system, which can result in damage.

SPECIFICATIONS

INTERFACES

FortiVoice model	FVC-24	FVC-48	FVC-84
Telephone lines (FXO)	2	4	8
Analog extensions (FXS)	4	8	4
VoIP ports*	8	8	8
VoIP numbers	24	24	24
Local extensions (Analog and IP)	16, expandable to 24	24, expandable to 32	32

* available with purchase of VoIP license

INTERFACE SPECIFICATIONS

LAN interface	RJ-45 Ethernet (10/100BaseT)
Memory	4 hours internal, expandable to 12 hours
Music input	Phono jack (1/8" mono) or stored .wav file
PA output	Phono jack (1/8" mono)
Power source	Input: 100-240 VAC 50/60 Hz Output: 18 VDC 1.5 A
Power-failure line to extension jacks	Extension 4 connects to Line 1. Note: Does NOT apply in AU.
USB host	Future feature

ANALOG EXTENSION SPECIFICATIONS

Connector type	RJ-11, 2-pin
Trunk type	Loop start
Interface impedance	Either 600 Ω , 900 Ω , TBR21, BT complex, AU complex or ZA complex, depending on region.
Loop range	0–600 Ω
Flash supported	Yes
On-hook voltage	35 V
Off-hook loop voltage source	35 V
Off-hook loop current	23 mA to 40 mA
Dial tone level	-2.4 dBm
Ringing voltage	90 V RMS
Ringing frequency	20 Hz or 25 Hz (depending on region) – True sine wave
Total ringing load	5 REN

TELEPHONE LINE SPECIFICATIONS

Connector type	RJ-11, 2-pin
Trunk type	Loop start
Interface impedance	Configurable, 600 Ω , 600 complex, 900 Ω , 900 complex
Ringing impedance	3,900 Ω
Ringing sensitivity	45 V RMS @ 20 Hz or 25 Hz (depending on region)
REN	0.7 B
Longitudinal balance	69 dB
Signal level	-10 dB
Distinctive ring supported	Yes
Caller ID support	FSK, all lines

DIMENSIONS

Metric (mm)	51.6 x 203.2 x 213.4
Imperial (inches)	2.03 x 8.0 x 8.4

WEIGHT

FortiVoice Model	FVC-24	FVC-48	FVC-84
Metric (kg)	0.67	0.81	0.91
Imperial (lbs)	1.46	1.77	1.99

REGULATORY APPROVALS



ACTA TIA/EIA/IS-968A and FCC Part 68, Industry Canada CS-03
FCC Part 15B, Industry Canada ICES-003

System and power adapter comply with UL and CSA

Reduction of Hazardous Substances (RoHS) Directive 2002/95/EC

VOIP FEATURES

- Embedded SIP server for IP extensions
- G.711 μ -law/A-law
- G.168 echo cancellation
- VAD, silence suppression
- Adaptive jitter buffer
- Packet loss concealment
- 8 concurrent VoIP sessions

With optional VoIP Trunking license:

- Multibranch VoIP networking
- Up to 4 service provider accounts
- G.729a codec
- Fax tone detection

INSTALLATION

UPGRADING SYSTEMS

As your business grows, you can add capacity for telephone lines, VoIP lines and extensions to the systems. You can add capacity in several ways:

Add units to your network: Up to 4 units can be combined for more line and extension capacity.

Add an upgrade to your system: Some models can be upgraded. Check the hardware specification guide for your model.

UNIT FRONT PANEL

The front panel consists of a power button, 4 line lights, and the power/data light.



Light	State	Description
Line 1 to Line 4	On	Line is in use.
	Flickering	Line is ringing.
	Pulsing slowly	Line caller is on hold.
	Pulsing quickly	Line is engaged by a device that is sharing the line with the system.
Power/Data	On	System is powered on.
	Pulsing slowly	A voicemail message has been left in one of the mailboxes. This indicator is disabled by default, but can be enabled.

Phone system models with 8 telephone lines do not have lights for Lines 5 to 8.

What the flashing lights mean

A unit flashes the lights on the front panel in patterns to show system activity and diagnostic conditions, as described in Chapter 6 of the *FortiVoice User Guide*.

Unit back panel

The PF box between E4 and L1 represents power failure support. In the event of a power failure or loss of power to the system, extension jack E4 is able to receive and make calls on Line 1. Note: not applicable in Australia.

HOME/OFFICE WIRING INSTRUCTIONS

This section describes phone wiring for North America, and is provided as reference information for other countries and regions.

UNITED KINGDOM — To connect telephones with BT style plugs, it is recommended that extensions are wired through a master socket or an in-line adapter with a capacitor. This also ensures compatibility with some telephones that require 3-wire connections for the telephone to ring.

BASIC RESIDENTIAL PHONE WIRING

Looped wiring

Loop wiring is common in most residential houses. The demarcation point (see next page) breaks the incoming phone lines into 'loops' that can run the length of the entire house, but are often broken into smaller loops that serve different areas of the house.

All houses have at least one telephone line, however it is also common to have two or more incoming phone lines. Whether you are wiring single, dual or multiple lines, you will still be using phone cord with four wires. How each phone jack is wired to the loops will determine if the phone jack is on Line 1 or Line 2.

This document describes single- and two-line wiring configurations. Many of the processes can also be applied to multi-line wiring.

Single-line wiring



For a single telephone line, all phones in the building will usually be wired using the RED and GREEN wires of the phone cord. The other two wires, BLACK and YELLOW, are not used.

The demarcation point connects the incoming RED and GREEN pair to various loops within the building. It is probable that the building is also wired with a BLACK and YELLOW pair, however these are not connected to any wall jacks.

Two-line wiring

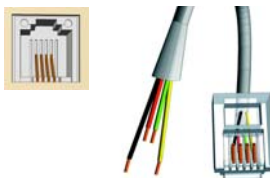

Two incoming phone lines are denoted in pairs, usually the RED and GREEN are used as Line 1, and the BLACK and YELLOW are Line 2. All four wires are looped throughout the building so that each jack has access to Line 1 and Line 2. How each jack is connected to the RED, GREEN, BLACK, and YELLOW wires determines if it is connected to Line 1, Line 2, or both.

Demarcation point

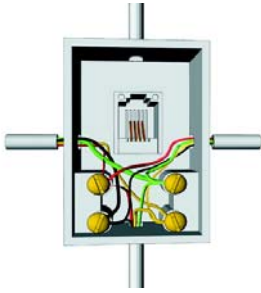

The demarcation point is the point of interconnection between the telephone company facilities and your building.

Location: It is usually a box located inside the building, within 15 feet of the incoming phone wiring. In newer houses, it may be located near the fuse box.

Wiring: The box will contain at least four posts used to branch the incoming wiring to the internal phone wiring. The RED post should have all the RED wires attached to it, the GREEN should have all the GREEN wires attached etc.

This demarcation point shows two loops. Each loop has two lines (four wires). Depending on how the jack is wired, the phone can be plugged into Line 1, Line 2, or both.

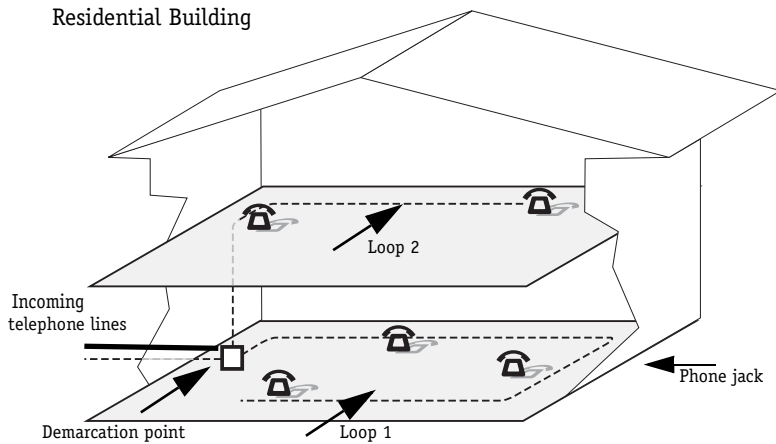

HOME AND HOME OFFICE WIRING PRIOR TO ADDING YOUR PHONE SYSTEM

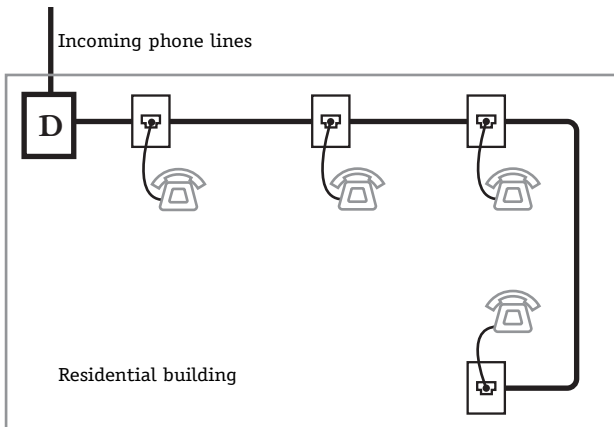

All phones are connected together in a single loop (or in multiple loops).

The phones are all wired to Line 1. If you have two or more incoming lines, the phones can be wired to Line 1, Line 2 or even both lines for two-line phones.

Prior to adding a your phone system, all phones in the home ring in unison when a call comes in. Home phones do not have phone system functionality and rely on phone company features for any enhancements.

Re-wiring the demarcation point

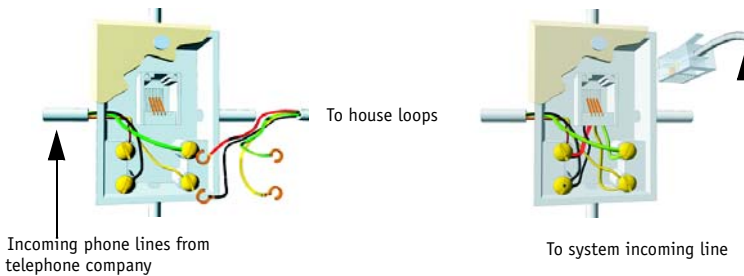

1. Loosen the screws connecting the wires to the posts.
2. Disconnect all house loops.
3. Connect a phone cable that will run to the extension block.
4. Tighten the screws connecting the wires to the posts.

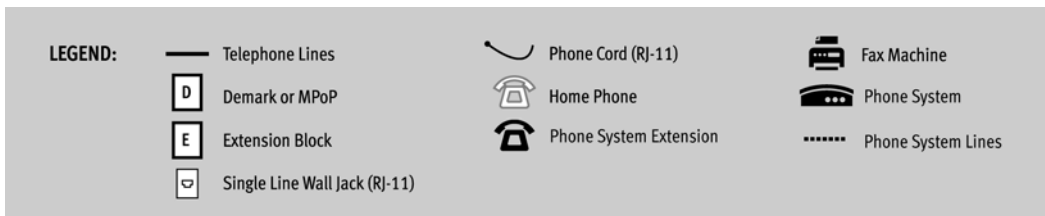

Adding an extension block

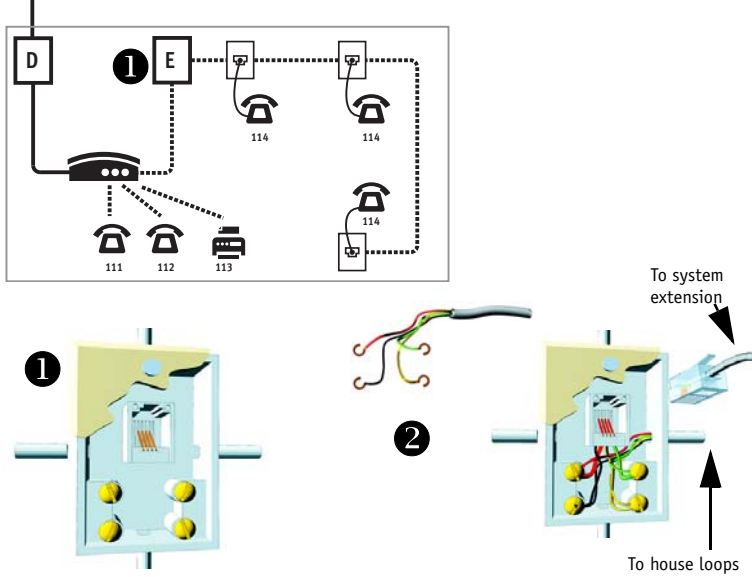

1. Add an extension block next to the demarcation point.
2. Connect the house loops and the phone cable from the demarcation point to the posts of the extension block.

LEGEND:	Telephone Lines	Phone Cord (RJ-11)	Fax Machine
	Demark or MPoP	Home Phone	Phone System
	Extension Block	Phone System Extension	Phone System Lines
	Single Line Wall Jack (RJ-11)		

Connecting to the system

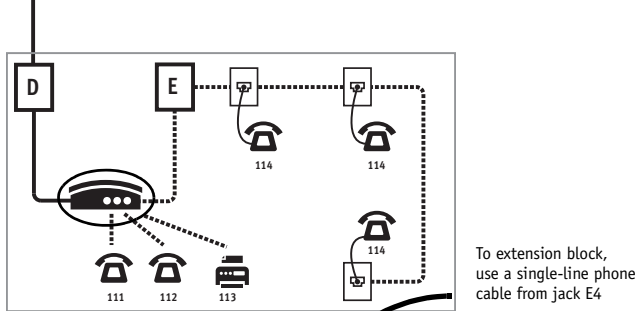

Connecting to the rear panel

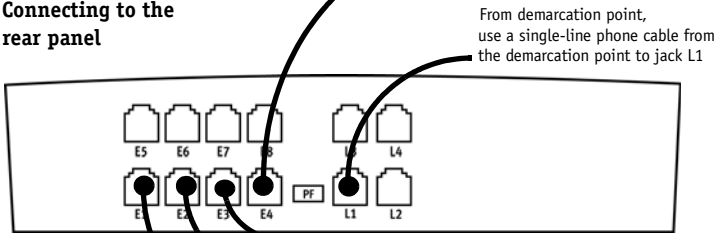

- Ext 113: To fax machine (optional) from jack E3
- Ext 112: To phone from jack E2
- Ext 111: To phone from jack E1

To office extensions, phones and fax machines

RJ-11 cabling can go up to 100 feet from the system without affecting voice quality. You may extend the lines farther although you may suffer voice quality.

Cabling can be run along baseboards, moldings, threaded between walls, and hidden under carpets. Keep the cords in corners and along edges to help hide it, and avoid high traffic areas.

1. Use a single-line RJ-11 phone cord to connect the demarcation point to the system's L1.
2. Use a single-line RJ-11 phone cord to connect the extension block to the system's E4.
3. Use single-line RJ-11 phone cords to connect the office phones to the system's E1, E2 and E3.

LEGEND:	Telephone Lines	Phone Cord (RJ-11)	Fax Machine
	Demark or MPoP	Home Phone	Phone System
	Extension Block	Phone System Extension	Phone System Lines
	Single Line Wall Jack (RJ-11)		

SAFETY AND REGULATORY INFORMATION

SAFETY PRECAUTIONS

Before using the system, please review and ensure the following safety instructions are adhered to:

1. Read, follow and retain instructions — All safety and operating instructions should be read, followed and retained for future reference before operating the equipment.
2. Heed warnings — All warnings on the equipment and in the operating instructions should be adhered to.
3. Temperature — Do not operate in environments where the temperature is below 0°C or 32°F. If the product was shipped in cold weather, please let the system warm up at room temperature for at least two hours before plugging it in to a power outlet.
4. Moisture — Do not place the system in a high-humidity environment.
5. Heat — Never place the system near heat sources such as radiators, floor registers or in direct sunlight. Do not stack units on top of each other.
6. Power supply — The equipment should only be connected to an approved power supply of the type described in the operating instructions or marked on the equipment. Use only the power adapter supplied with the system.
7. Damage requiring service — Do not attempt to service the system yourself. Unplug the system and refer servicing to a licensed technician when:
 - The plug or power cord has been damaged.
 - The system has been exposed to moisture.
8. Emergency services — If you call an emergency service using an external IP extension, the system will not send the address of your location. You must provide your address to the emergency operator.

EXTERNAL AUDIO SOURCE ISOLATION

We recommend that any external audio source be connected to the unit using an approved Line Isolation Unit (e.g. A-Tick () approved in AU).

Call Redirection & Service Provider Billing Advisory

Use of the automatic route selection, toll restriction and Call Detail Recording features does not imply any guarantee whatsoever by regulatory authorities, your telephone service provider(s), the company or its distributors and resellers, with regard to the accuracy of these features and that the use of such a features may not be considered by a telephone company in any disputes which may arise regarding the accuracy of any subscriber's telephone account.

IMPORTANT NOTICES

CE Compliance

The product models listed below comply with the essential requirements of the European “Radio and Telecom Terminal Equipment” (R&TTE) directive 1999/5/EC, and are for connection to regular telephone lines (PSTN). This equipment has been tested and found to comply with the following standards:

EN55022:1998 + amendment A1:2000 + amendment A2:2003, Class B
EN55024:1998 + amendment A1:2001 + amendment A2:2003
EN60950-1:2001, first edition
EN61000-3-2:2000
EN61000-3-3:1995+ amendment A1:2001
CISPR22:1997 + amendment A1:2000 + amendment A2:2002

 This equipment is marked with the CE symbol, indicating compliance with CE standards.

FCC and IC Warnings

This equipment complies with ACTA TIA/EIA/IS-968A and Part 68 of the Federal Communications Commission (FCC) rules in the United States. It also complies with regulations RSS210 and CS-03 of Industry Canada and Science Canada. This equipment also complies with Part 15 of the FCC Rules, as well as ICES003 of Industry Canada. Operation is subject to the following two conditions: (1) this device may not cause harmful interference, and (2) this device must accept any interference received, including interference that may cause undesired operation of the device.

FCC Part 15

This equipment has been tested and found to comply with the limits for a “CLASS B” Digital Device pursuant to Part 15 of the FCC rules. These limits are designed to provide a reasonable protection against harmful interference in a residential installation. This equipment generates, uses and can radiate radio frequency energy, and if not installed and used in accordance with these instructions, may cause harmful interference to radio communications. However, there is no guarantee that interference will not occur in a particular installation. If this equipment does cause harmful interference to radio or television reception, which can be determined by turning the equipment off and on, the user is encouraged to try to correct the interference by one or more of the following measures:

- Reorient or relocate the receiving antenna.
- Increase the separation between the equipment and receiver.
- Connect the equipment to an outlet on a circuit different to that which the receiver is connected.
- Consult the dealer or an experienced Radio/TV technician for help.

This CLASS B Digital apparatus meets all requirements of the Canadian interference-causing equipment regulations.

Changes or modifications not expressly approved by FortiVoice could void the user’s authority to operate the equipment.

ACTA TIA/EIA/IS-968A, FCC Part 68 and IC CS-03

Notice: The Industry Canada label identifies certified equipment. This certification means the equipment meets telecommunications network protective, operational and safety requirements as prescribed in the appropriate Terminal Equipment Technical Requirements document(s). The department does not guarantee the equipment will operate to the user’s satisfaction.

Before installing this equipment, users should ensure it is permissible to be connected to the facilities of the local telecommunications company. The equipment must also be installed using an acceptable method of connection. The customer should be aware that compliance with the above conditions may not prevent degradation of service in some situations.

Repairs to certified equipment should be coordinated by a representative designated by the supplier. Any repairs or alterations made by the user to this equipment, or equipment malfunctions, may give the telecommunications company cause to request the user to disconnect the equipment.

Users should ensure, for their own protection, that the electrical ground connections of the power utility, telephone lines and internal metallic water pipe system, if present, are connected together. This precaution may be particularly important in rural areas.



Caution: Users should not attempt to make such connections themselves, but should contact the appropriate electric inspection authority, or electrician, as appropriate.

A label is located on the underside of the base unit containing both the FCC registration number and Ringer Equivalency Number (REN) or the IC registration number and Load Number. You must, upon request, provide this information to your local telephone company.

The REN is used to determine the quantity of devices that may be connected to the telephone line. Excessive RENs on the telephone line may result in the devices not ringing in response to an incoming call. In most, but not all areas, the sum of RENs should not exceed five (5). To be certain of the number of devices that may be connected to a line, as determined by the total RENs, contact the local telephone company.

This equipment is compatible with inductively-coupled hearing aids.

If the equipment is causing harm to the telephone network, the telephone company may request that you disconnect the equipment until the problem is corrected.

This equipment cannot be used on public coin telephone services provided by the telephone company. Connection to party line service is subject to state tariffs.

The FCC requires that you connect your cordless telephone to the nation-wide telephone network through a modular telephone jack (USOC, RF11C, RJ11W, or RJ14).

Your telephone company may discontinue your service if your equipment causes harm to the telephone network. They will notify you in advance of disconnection, if possible. During notification, you will be informed of your right to file a complaint to the FCC.

Occasionally, your telephone company may make changes in its facilities, equipment, operation, or procedures that could affect the operation of your equipment. If so, you will be given advance notice of the change to give you an opportunity to maintain uninterrupted service.

DOC Compliance

This digital apparatus does not exceed the Class B limits for radio noise emissions for digital apparatus as set out in the Radio Interference Regulations of the Canadian Department of Communications.

ICASA

For all ICASA license enquiries, please contact your South African authorized distributor for your phone system.

RoHS Compliance

This equipment conforms with the Reduction of Hazardous Substances (RoHS) Directive 2002/95/EC. The RoHS directive provides for restriction or elimination of the following substances:

- Lead, mercury, cadmium, hexavalent chromium, polybrominated biphenyls (PBB), and polybrominated diphenyl ether (PBDE).

RoHS and related legislations are initiatives to reduce the environmental issues related to the manufacture of electronic equipment.

Disposal



At the end of the product's life, please ensure disposal is in compliance with local regulations for electrical and electronic waste.

FORTINET[®]

www.fortinet.com